

Instruction Manual

Triaxial Vibration Monitor VM40A/B



Manfred Weber

Metra Mess- und Frequenztechnik in Radebeul e.K.

Meissner Str. 58 - D-01445 Radebeul

Tel. +49-351 836 2191 Fax +49-351 836 2940

Email: Info@MMF.de Internet: www.MMF.de

Published by:

Manfred Weber

Metra Mess- und Frequenztechnik in Radebeul e.K.

Meißner Str. 58

D-01445 Radebeul

Tel. +49-351-836 2191

Fax +49-351-836 2940

Email Info@MMF.de

Internet www.MMF.de

Note: The latest version of this manual can be found at
http://www.mmf.de/product_literature.htm

Specification subject to change.

© 2014 Manfred Weber Metra Mess- und Frequenztechnik in Radebeul e.K.

Full or partial reproduction subject to prior written approval.

Contents

| | |
|--|----|
| 1. Purpose of Use..... | 2 |
| 2. Function..... | 2 |
| 3. Measuring..... | 3 |
| 3.1. Selecting the Measuring Mode..... | 3 |
| 3.2. Measuring in accordance with DIN 4150-3..... | 4 |
| 3.2.1. Measurement Procedure..... | 4 |
| 3.2.2. Measuring with the VM40..... | 6 |
| 3.3. Measuring in accordance with BS7385..... | 8 |
| 3.3.1. Measurement Procedure..... | 8 |
| 3.3.2. Measuring with the VM40..... | 9 |
| 3.4. Measuring in accordance with SN 640312a..... | 10 |
| 3.4.1. Measurement Procedure..... | 10 |
| 3.4.2. Measuring with the VM40..... | 11 |
| 3.5. Measurement in accordance with Circulaire 23/07/86..... | 12 |
| 3.5.1. Measurement Procedure..... | 12 |
| 3.5.2. Measuring with the VM40..... | 13 |
| 3.6. Non-Standardized Measuring..... | 13 |
| 3.7. Overload Indication..... | 14 |
| 4. Saving Measurement Values..... | 15 |
| 4.1. Introduction..... | 15 |
| 4.2. Settings for Recording Data..... | 16 |
| 4.3. Viewing saved Data..... | 18 |
| 4.4. Deleting the Data Memory..... | 19 |
| 4.5. Event Reporting..... | 19 |
| 4.6. Transferring the recorded data to a PC..... | 19 |
| 5. Relay Output..... | 19 |
| 6. Receiving Alerts via SMS (VM40B)..... | 21 |
| 6.1. General Information..... | 21 |
| 6.2. Inserting the SIM Card..... | 21 |
| 6.3. Connecting to a Mobile Phone Network..... | 23 |
| 6.4. SMS Alerts..... | 24 |
| 6.5. Phone Book..... | 26 |
| 6.6. Writing an SMS..... | 26 |
| 6.7. Calling..... | 27 |
| 6.8. Close connection with mobile phone network..... | 28 |
| 7. Miscellaneous Settings..... | 28 |
| 7.1. Warning Threshold..... | 28 |
| 7.2. Keypad Lock..... | 29 |
| 7.3. Adjusting the Axes..... | 29 |
| 7.4. Date and Time..... | 30 |
| 7.5. Instrument Name..... | 30 |
| 7.6. Menu Language..... | 31 |
| 8. Data Transfer..... | 31 |
| 8.1. Connection to a PC..... | 31 |
| 8.2. Software VM40MDB..... | 31 |
| 9. Firmware Update..... | 37 |
| 10. Charging the Accumulator..... | 38 |
| 11. External Power Supply..... | 39 |
| 12. Reset..... | 39 |
| 13. Mounting / Installation..... | 40 |
| 14. Calibration..... | 41 |
| 15. Technical Data..... | 42 |
| Appendix: Guarantee | |
| CE Declaration of Conformity | |

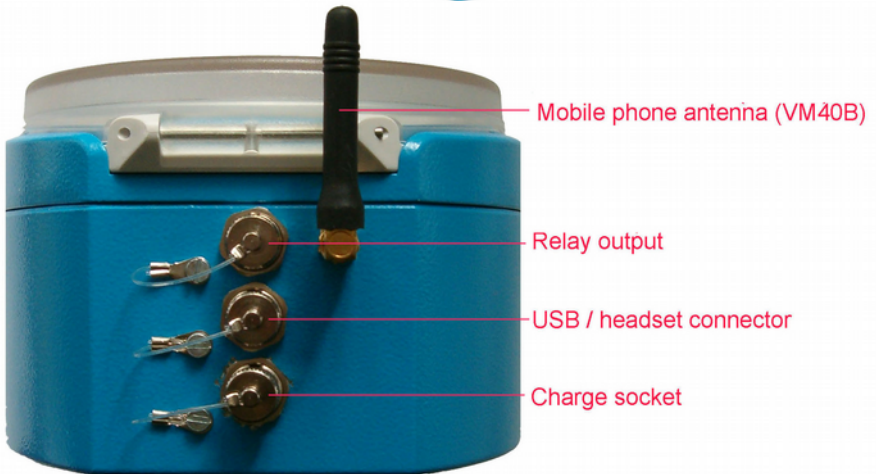

Thank you for choosing a Metra Vibration Measurement Instrument

1. Purpose of Use

The VM40 is designed for measuring vibration in buildings, bridges, towers, pipelines and various other large structures.

The measurements serve to prevent possible structural damage or disturbance to people.

The VM40 contains a sensor, recording and evaluation electronics and an accumulator in its robust casing. It is especially suitable for autonomous operation over longer periods of time e.g. on construction sites.

2. Function

The instrument contains three highly sensitive piezoelectric systems for vibration measurement of all three spacial dimensions.

The signal processing is controlled by a micro processor. The VM40 is operated via its seven keypad buttons and illuminated LCD display.

The measurement data can be transferred to a PC via the USB interface. The instrument also has a port for connecting a charger and a relay output for the external signaling of vibration occurrences.

The VM40 can measure in accordance with to the following standards:

- **DIN 4150-3**: Structural Vibration – Effects of vibration on structures
- **BS 7385**: Evaluation and measurement for vibration in buildings
- **SN 640312a**: Effects of vibrations on buildings
- **Circulaire du 23/07/86** relative vibrations mécaniques émises dans l'environnement par les installations classées pour la protection de l'environnement

Through menu navigation, all information concerning the type and location of the measurement and the building type is requested and operational errors are avoided.

The display of the measurement values is carried out using the three peak values of vibration velocity (X/Y/Z) or the vector sum. Furthermore the main frequency and its coordinate are displayed for the highest amplitude.

Additionally the VM40 displays the FFT spectrum of the measured vibration quantity. The spectral graph also indicates the limit value curve of the chosen standard, which enables you to analyze potential damage at a glance.

If the limit value is exceeded, the measured value can be saved. The VM40 also contains two LEDs and a relay output for signaling alarm status.

The VM40B also has the option of sending an SMS report, via its built-in GSM modem, if a limit value is exceeded.

3. Measuring

3.1. Selecting the Measuring Mode

Switch on the VM40 by pressing the ON-OFF button. After the start screen, the measurement value display with the most recently selected settings appears.

Press F3 to open the main window and select "measuring mode" (Figure 1).

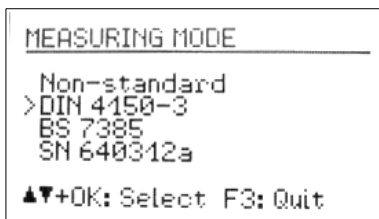

Figure 1: Measuring mode

You can choose between adjustable measured value (non-standardized) and the three supported standards, which are described in the following sections.

In the measurement value display you can view the selected settings by pressing the F1 button (Figure 2).

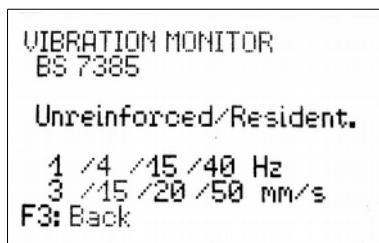

Figure 2: Settings display

Here you will see your chosen standard with its specified settings as well as the four frequency and amplitude dots of the limit value curve.

Notice: The following chapters include abstracts of the most relevant standards for building vibration. For a compliant evaluation it is necessary to study the standard documents to the full extent.

3.2. Measuring in accordance with DIN 4150-3

3.2.1. Measurement Procedure

DIN 4150-3 is the most widely applied standard internationally for measuring structural vibrations. The measurement procedure can be found in a similar form in other national standards, for example the Italian UNI 9916.

The assessment parameter is the maximum value v_i of the three individual components (peak values) of vibration velocity at frequencies of 1 to 80 Hz. The measurements are carried out at the foundation. Vibrations in the ceiling of the upper most outer walls also provide valuable information for analysis. These detect the horizontal response of the building to the vibration at the foundation. Only the greatest value of both the horizontal components is then used for the analysis.

The standard provides guide values for permissible vibration velocities for short-time and sustained vibrations in three types of buildings.

| Guide values for vibration velocity v_i for analyzing the effects of transient vibration | | | | | |
|--|--|--------------|--------------|-----------------|---------|
| Building Type | Foundation | | | Upper ceiling | |
| | Frequency of the Significant Vibration | | | | |
| Frequency range | 1 – 10 Hz | 10 – 50 Hz | 50 – 100 Hz | all Frequencies | |
| Direction | X / Y / Z | X / Y / Z | X / Y / Z | X / Y | Z |
| Reinforced or framed structures. Industrial and heavy commercial buildings | 20 mm/s | 20 – 40 mm/s | 40 – 50 mm/s | 40 mm/s | 20 mm/s |
| Unreinforced or light framed structures/ Residential or light commercial type buildings | 5 mm/s | 5 – 15 mm/s | 15 – 20 mm/s | 15 mm/s | 20 mm/s |
| Delicate, listed buildings e.g. historical monuments | 3 mm/s | 3 – 8 mm/s | 8 – 10 mm/s | 8 mm/s | 20 mm/s |

Table 1: Guide values for transient vibration

Notes from DIN 4150-3 about the guide values in Table 1:

- For engineering structures in massive scale construction, e.g. reinforced concrete for abutments or block foundations you can raise the guide values for industrial type buildings twofold.
- If short-time vibrations occur in ceilings at below 20 mm/s in vertical direction, a reduction in the serviceability is not to be expected.

The standard also gives guide values for short-time vibrations on pipelines of varying types:

| Guide values for transient vibrations in pipelines | |
|--|--------------------------|
| Pipe material | Vibration Velocity v_i |
| Steel, welded | 100 mm/s |
| Stoneware, concrete, reinforced concrete, pre-stressed concrete, metal | 80 mm/s |
| Brickwork, plastic | 50 mm/s |

Table 2: Guide values for pipelines

For continuous vibrations the following guide values apply:

| Guide values for vibration velocity v_i for analyzing the effects of continuous vibration | | |
|---|--------------------------------------|--------------|
| Building Type | Upper ceiling level, all Frequencies | |
| Direction | X / Y (horizontal) | Z (vertical) |
| Reinforced or framed structures industrial and heavy commercial buildings | 10 mm/s | 10 mm/s |
| Unreinforced or light framed structures, residential or light commercial type buildings | 5 mm/s | 10 mm/s |
| Delicate buildings, listed buildings e.g. historical monuments | 2.5 mm/s | - |

Table 3: Guide values for continuous vibration

Vertical continuous vibrations with a vibration velocity below 10 mm/s normally do not cause damage to ceilings in houses. For delicate buildings there are no guide values available.

For sustained vibrations on pipelines, the guide values for short time vibrations, reduced by 50%, can be applied.

The following advice is given in DIN 4150-3 for the placement of sensors:

- For foundation vibrations the transducer should be placed on the lowest floor at the foundation or on the outer wall.
- In the upper ceiling level the sensor should be placed inside or very close to the outer wall.
- For buildings without a basement the measurement location must not be higher than 0.5m above the ground level.
- The measurement location should predominantly be on the side of the building facing the excitation.
- One of the lateral coordinates (X / Y) should be parallel to an outside edge of the building.
- Buildings with larger ground areas should be measured at several points.
- In addition to measuring at the foundation and the upper ceiling, if required, measurements can be carried out in the vertical direction on the ceilings, where the strongest vibrations are to be expected (mostly central).
- When measuring pipelines, where possible, the sensor should be placed on the pipeline itself

3.2.2. Measuring with the VM40

After choosing the operating mode „DIN 4150-3“, please select whether you will be measuring short-time or sustained vibrations (Figure 3).

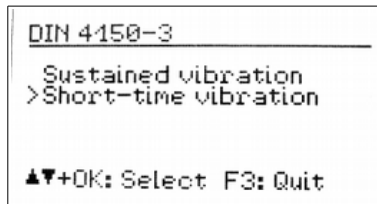

Figure 3: Short-time/Sustained vibration

Next, please select the building type:

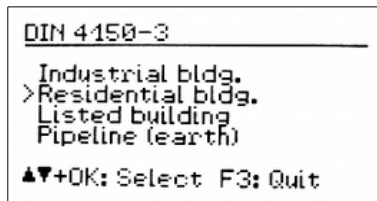

Figure 4: Building type

When selecting “Pipeline” the following types are available:

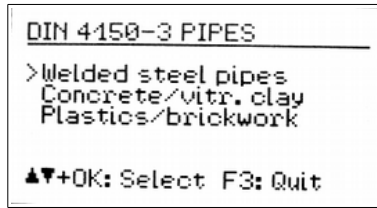

Figure 5: Pipeline types

In the case of short-time vibrations the measurement location needs to be selected:

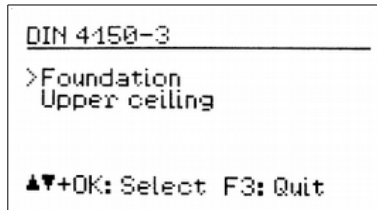

Figure 6: Measurement location

The standard frequency range is 1 to 80 Hz. In special cases, e.g. blasting operations, the frequency range can be increased to 1 to 315 Hz.

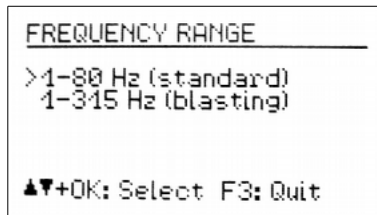

Figure 7: Frequency range

Press F3 to exit the menu to go to the measurement value display (Figure 8).

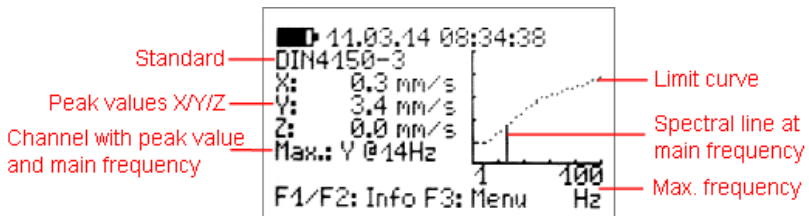

Figure 8: Measurement value display in accordance with DIN 4150-3

The three peak values X/Y/Z of the vibration velocity and the highest amplitude together with its main frequency are displayed every second. On the right side of the screen a graph displays this value in the frequency range. The diagram is scaled to the limit curve. Higher magnitudes will be cut off.

Notice: For ceiling vibrations (1 and 3) there are different guide values for the vertical (Z) direction. They are evaluated by the VM40 and considered for alarms. In the FFT and frequency display, however, only the horizontal directions (X / Y) are shown.

If the limit value curve is exceeded, “ALARM” is displayed below the main frequency. If the limit value is exceeded the following will happen:

- The red light will flash.
- The measurement values will be saved if the event recording has been activated.
- The relay output will switch, if it has been activated.
- A text message (SMS) will be sent, if this option has been set up on the VM40B.

Note: The alarm and recording functions will be activated after a delay of 30 seconds after leaving the menu.

3.3. Measuring in accordance with BS7385

3.3.1. Measurement Procedure

The British Standard BS 7385 is mainly used in the Commonwealth countries. It is less complex than the DIN Standard. Similarly to the DIN standard, it also measures the peak value of the vibration velocity in all spacial dimensions. It is called “peak particle velocity” (ppv). The frequency range is not precisely specified. The VM40 uses the range 1 to 80 Hz and 1 to 315 Hz.

The Standard provides guide values for short-time vibrations, which are measured at the foundation (Table 4). The guide values mark the limit above which cosmetic damage may occur, such as cracks in the walls or ceilings. Lesser damage is to be expected at double the guide value and greater damage at fourfold the guide value. In the case of sustained vibrations or excitation from building resonance the guide values need to be reduced by at least 50%.

Residential and Industrial buildings are differentiated.

| Guide values for short-time vibrations without excitation of building resonances | | |
|---|--|---|
| Main Frequency | Vibration Velocity for Residential Buildings | Vibration Velocity for Industrial Buildings |
| 1 – 4 Hz | < 0.6 mm displacement | - |
| 4 Hz | 15 mm/s | 50 mm/s |
| 15 Hz | 20 mm/s | 50 mm/s |
| 40 Hz | 50 mm/s | 50 mm/s |
| 250 Hz | 50 mm/s | 50 mm/s |

Table 4: Guide values in accordance with BS 7385

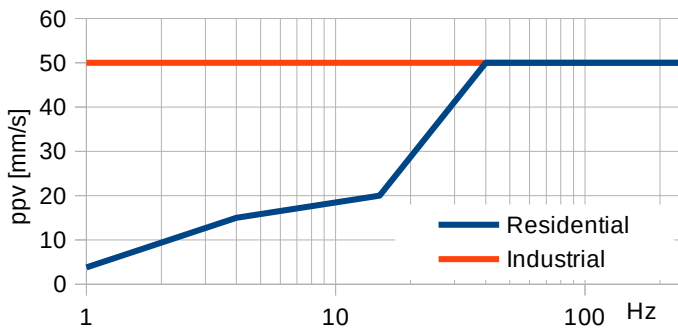

Figure 9: Graph: Guide values in accordance with BS 7385

3.3.2. Measuring with the VM40

Once you have selected the measuring mode “BS7385”, select the building type to be assessed (Figure 10).

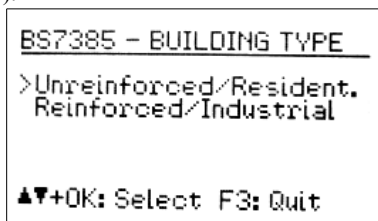

Figure 10: Building Type

In the next menu select the frequency range:

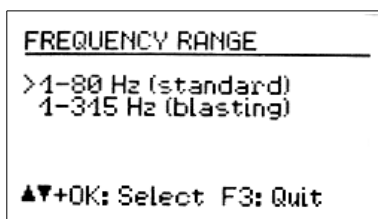

Figure 11: Frequency range

Press F3 to exit the menu and to go the measurement value display (Figure 12).

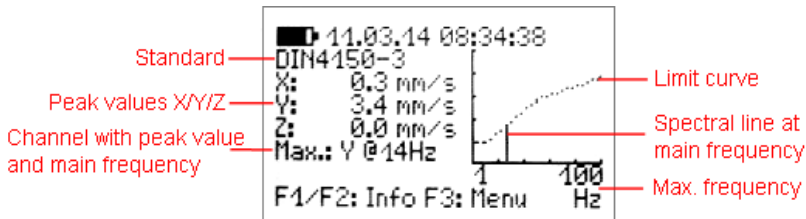

Figure 12: Measurement value display to BS7385

The three peak values X/Y/Z of the vibration velocity and the highest amplitude together with its main frequency are displayed every second. On the right side of the screen a graph displays this value in the frequency range. The diagram is scaled to the limit curve. Higher magnitudes will be cut off.

If the limit value is exceeded, “ALARM” is displayed below the main frequency and the following will happen:

- The red light will flash.
- The measurement values will be saved if the event recording has been activated.
- The relay output will switch off, if it has been activated.
- An SMS will be sent, if this option has been set up on the VM40B.

Note: The alarm and recording functions will be activated after a delay of 30 seconds after leaving the menu.

3.4. Measuring in accordance with SN 640312a

3.4.1. Measurement Procedure

The Swiss Standard SN 640312a is also based on the peak values of the vibration velocity. However, it uses the vector sum as assessment parameter:

$$v_i = \sqrt{v_x^2 + v_y^2 + v_z^2}$$

It measures between 5 and 150 Hz. The frequency range is divided into three sections: 8 to 30 Hz, 30 to 60 Hz and > 60 Hz. For frequencies below 8 Hz the guide value for 8 to 30 Hz reduced by one-third is applied.

As a basis for the guide values, four building types with different levels of sensitivity, the occurrence of vibrations and the frequency with which the vibration influence occurs are taken as a the basis for the guide values (5).

| Occurrence of vibrations | very low sensitivity | | | low sensitivity | | | normal sensitivity | | | increased sensitivity | | |
|--------------------------|----------------------|------------|-------------|-----------------|------------|-------------|--------------------|------------|-------------|-----------------------|------------|-------------|
| | occasionally | frequently | permanently | occasionally | frequently | permanently | occasionally | frequently | permanently | occasionally | frequently | permanently |
| 1 Hz | 45 mm/s | 18 mm/s | 9 mm/s | 30 mm/s | 12 mm/s | 6 mm/s | 15 mm/s | 6 mm/s | 3 mm/s | 7.5 mm/s | 3 mm/s | 1.5 mm/s |
| 30 Hz | 60 mm/s | 24 mm/s | 12 mm/s | 40 mm/s | 16 mm/s | 8 mm/s | 20 mm/s | 8 mm/s | 4 mm/s | 10 mm/s | 4 mm/s | 2 mm/s |
| 60 Hz | 90 mm/s | 36 mm/s | 18 mm/s | 60 mm/s | 24 mm/s | 12 mm/s | 30 mm/s | 12 mm/s | 6 mm/s | 15 mm/s | 6 mm/s | 3 mm/s |

Table 5: Guide values in accordance with SN 640312a

3.4.2. Measuring with the VM40

After selecting the measuring mode “SN 640312a”, define which sensitivity class the building belongs to:

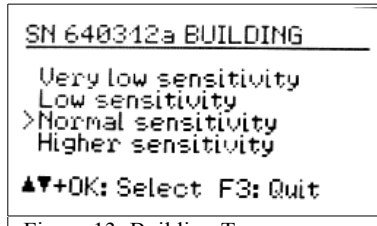

Figure 13: Building Type

Once you have selected the building type, select the occurrence of the vibrations. The figures represent the vibration emissions, at which the velocity vector exceeds the 0,7-fold guide value. The assessment period is the time duration during which the building is exposed to vibrations.

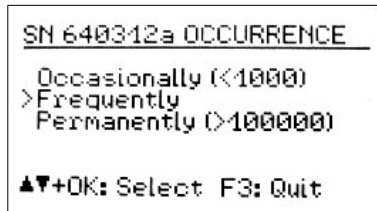

Figure 14: Occurrence

Press F3 to exit the menu and to go to the measurement value display (Figure 15).

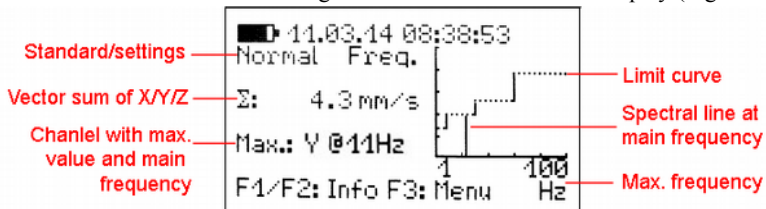

Figure 15: Measurement value display in accordance with SN 640312a

The vector sum of the vibration velocity in the three directions X/Y/Z and the highest amplitude together with its main frequency are displayed every second. On the right side of the screen a graph displays this value in the frequency range. The diagram is scaled to the limit curve. Higher magnitudes will be cut off.

If the limit value is exceeded, “ALARM” is displayed below the main frequency and the following will happen:

- The red light will flash.
- The measurement values will be saved if the event recording has been activated.
- The relay output will switch off, if it has been activated.
- An SMS will be sent, if this option has been set up on the VM40B.

Note: The alarm and recording functions will be activated after a delay of 30 seconds after leaving the menu.

3.5. Measurement in accordance with Circulaire 23/07/86

3.5.1. Measurement Procedure

The French guideline specifies a measuring method and limits for building vibration. It differentiates between methods for “fine analysis” and “monitoring”. The VM40 supports the second method. Measurement is based on the peak values of vibration velocity in directions X/Y/Z between 4 and 150 Hz..

Relevant for evaluation is the maximum of the three peak values and its main frequency. The guideline gives limit values for resistant, sensitive and very sensitive structures and for permanent or short-time vibration. The limit values are found in figures 16 and 17.

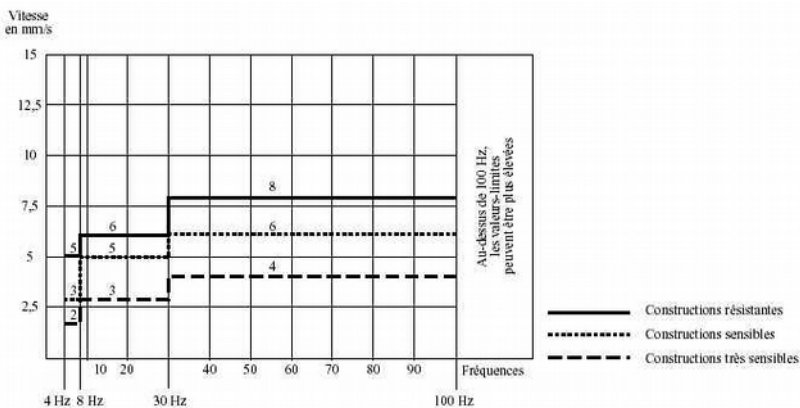

Figure 16: Limits for permanent vibration (Circulaire 23/07/86)

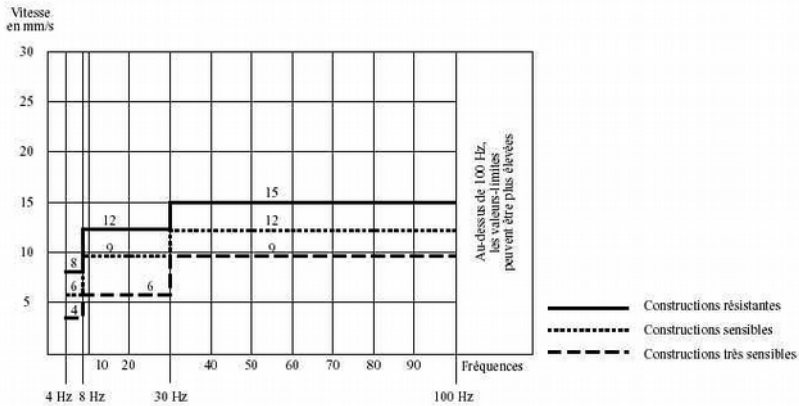

Figure 17: Limits for short-time vibration (Cirulaire 23/07/86)

3.5.2. Measuring with the VM40

After selecting the measuring mode “Cirulaire” you will be asked to enter the building type (resistant, sensitive or very sensitive). In the next step you select permanent or short-time vibration. Leave the menu by pressing F3.

The three peak values X/Y/Z of the vibration velocity and the highest amplitude together with its main frequency are displayed every second. On the right side of the screen a graph displays this value in the frequency range. The diagram is scaled to the limit curve. Higher magnitudes will be cut off.

If the limit value is exceeded, “ALARM” is displayed below the main frequency and the following will happen:

- The red light will flash.
- The measurement values will be saved if the event recording has been activated.
- The relay output will switch off, if it has been activated.
- An SMS will be sent, if this option has been set up on the VM40B.

Note: The alarm and recording functions will be activated after a delay of 30 seconds after leaving the menu.

3.6. Non-Standardized Measuring

If a standardized measurement is not desired, the vibration quantity (acceleration or velocity), the frequency range and the limit values can be entered manually. For this option select the measuring mode “Non-standardized”.

Next you can select the vibration quantity and frequency range (Figure 18).

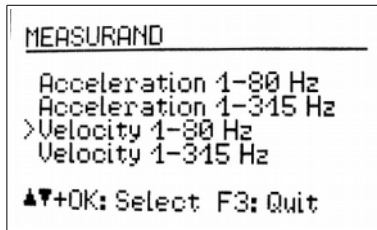

Figure 18: Non-standardized measurement

After this the points which define the limit value curve can be entered. The lowest and highest frequencies are fixed. The amplitudes and the two middle frequencies can be freely selected within the range limits. (Figure 19).

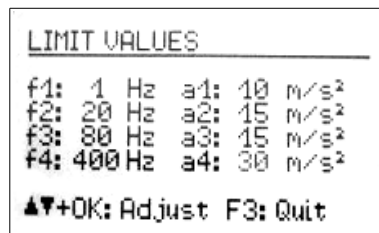

Figure 19: Entering limit values

As with the other measuring modes, your chosen measuring settings can be viewed during measuring by pressing F1 (Figure 20).

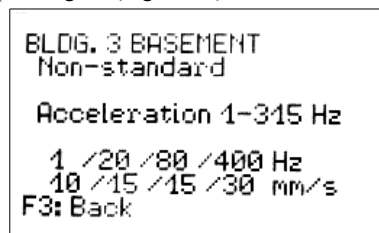

Figure 20: Display of limit values

3.7. Overload Indication

If the vibration magnitude exceeds the limits shown in the Technical Data section, the VM40 will indicate “OVERLOAD” instead of the measuring value for the respective direction. (Figure 21).

In addition the warning and alarm LEDs flash simultaneously.

Due to integration the overload limit for velocity is frequency dependent (Figure 22).

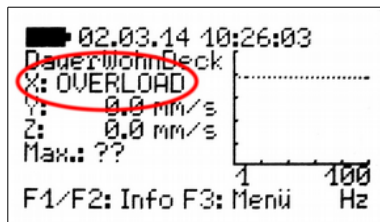

Figure 21: Overload indication

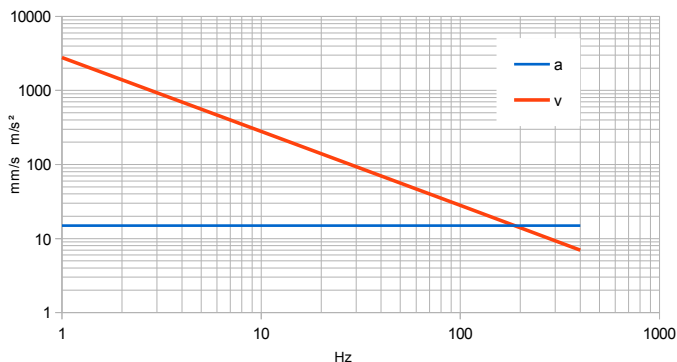

Figure 22: Overload limits for acceleration (a) and velocity (v)

4. Saving Measurement Values

4.1. Introduction

The VM40 has memory space for 100,000 measurements. The saved data can be viewed via the instrument menu or transferred to the PC via the USB interface.

A measurement record includes:

- Date and time
- Measurement values X/Y/Z or the vector sum
- Main frequency
- Trigger event

The instrument saves the data if any of the following events (triggers) occur:

- a warning or alarm event occurred
- a predefined time interval expired

Alarm events occur if the limits described in Section 3 are exceeded.

Warning events occur if the warning threshold is exceeded (see section 7.1).

The VM40 can also save measurements in fixed time intervals. In this case the highest X/Y/Z peak values since the last time step are saved¹. Thereby no vibration event

¹ from version 001.008, in earlier versions the current display value was saved

will be lost when recording in time intervals. This mode may be used if continuous recording is desired. It should be noted, however, that large amounts of data is accumulated withing short time. At 5 s recording interval, for example, the memory will be full after only 5 days. You should also be aware that it will take longer to transfer the data to a PC.

For most applications event controlled recording is sufficient. With carefully set alarm and warning limits all relevant vibration events are stored whereas time sections without vibration are ignored. This avoids the accumulation of useless data without information value. In any case the VM40 ensures continuous monitoring.

Notice: Saving measurements will start 30 seconds after leaving the menu.

Saved measurements are sorted in to data files in the VM40. A file contains related measurements with the same settings.

4.2. Settings for Recording Data

To start recording open the main menu by pressing F3 and select “Recording” (Figure 23).



Figure 23: Start Recording

Select “start”. Now you can define the events (triggers), when the data should be saved. (Figure 24).

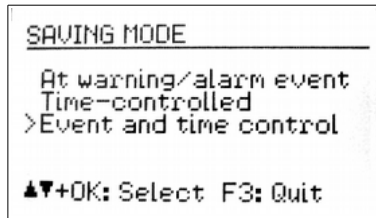

Figure 24: Trigger selection

In the setting “Warning/Alarm” the measurement value is saved as soon as a change in status occurs, as follows:

- Normal to Warning
- Normal to Alarm
- Warning to Alarm
- Alarm to Warning
- Alarm to Normal
- Warning to Normal

If the warning or alarm status persists, no further measured values will be saved. This keeps the quantity of saved data down to a minimum. The type of status change is saved with the measurement.

The VM40 also offers you the possibility of saving measurements at pre-set time intervals. The time intervals are to be entered in seconds, for a minimum of 5 seconds. (Figure 25).

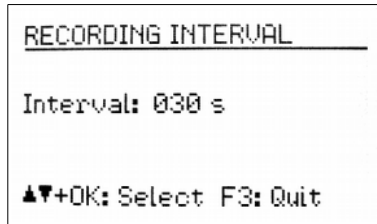

Figure 25: Recording interval

The time interval recording can also be combined with the status change recording (“Event and time control”).

After determining the recording settings you will be asked to enter the name of the data record (Figure 26).

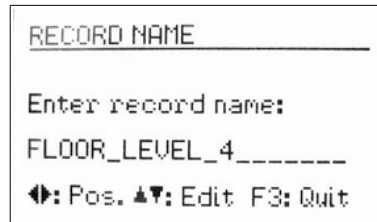

Figure 26: Record name

The record name identifies a block of related measurements with the same saved settings. Here you can enter, for example, the measurement location.

With the arrow keys you can enter up to 20 upper case characters and digits. The last entered name appears as the default name.

To exit the menu press OK. After defining all the recording settings you can activate the keypad lock by pressing OK, to ensure that no unwanted interference occurs (see Section 7.2). You can also start recording without using the keypad lock by pressing F3 (27).

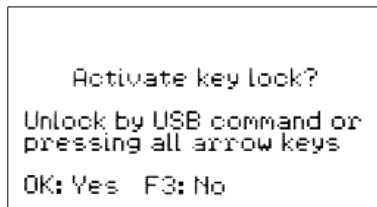

Figure 27: Key lock

The instrument will now display “Recording started”. Thirty seconds later the evaluation of the recording trigger (event or time interval) will begin. The currently ac-

tive recording can be seen in the measurement value display as a blinking text “Rec.# xxx”, where xxx is the number of the previously saved measurements.

During recording the menu cannot be opened. If you press the menu button F3 you will be asked whether you wish to stop recording, the same will happen if you press OK/ON-OFF.

After reaching the memory end the VM40 will display “Memory full”.

Notice: The transmission of data from the VM40 to the PC is not possible while recording is active.

4.3. Viewing saved Data

After recording you can view the saved measurements in the “Recording” menu. Select the menu point “View/edit/delete files” and then use the arrow keys ▲▼ to select the data file you wish to view (28).

```
File No. 2 of 3
FLOOR LEVEL 4
Start: 11.03.14 08:43:44
BS 7385 (1-80Hz)
unreinforced/Res.
5 s + events
F1: Edit name  ◀: Delete
▲▼+OK: Select  F3: Quit
```

Figure 28: Select file

A data file is displayed by its number and name, together with the start time, chosen standard and trigger source.

Note: The file numbers are not always in the order of saving. A previously erased file number will be re-assigned to the next saved file.

Pressing ◀ deletes the file together with all of its recorded measurements.

Press F1 to change the file name.

Press OK to open the file. The first saved record is then displayed (29). Below the file name you see the record number with the total number of records in the file, date and time and the trigger event. The abbreviations mean:

(T): time interval controlled

0→W: normal to warning transition

0→A: normal to alarm transition

W→A: warning to alarm transition

W→0: warning to normal transition

A→W: alarm to warning transition

A→0: alarm to normal transition

END: recording stopped by the user, last record

BAT: recording terminated because of discharged battery, last record

MEM: recording terminated because of full memory, last record

When the data was measured to SN 640312a you see the vector sum, otherwise the three measuring values of X / Y / Z. The significant frequency f(max) of the highest value is also displayed.

```
FLOOR LEVEL 4
Rec. No.1 of 5
11.03.14 08:43:44 (T)
X: 0.0 mm/s
Y: 0.7 mm/s
Z: 1.1 mm/s
f(max): 1 Hz
▲▼: Scroll F3: Quit
```

Figure 29: View record

Use keys ▲ ▼ to scroll between records. Press F3 to exit the menu.

4.4. Deleting the Data Memory

In the “Recording” menu the entire memory can be deleted by selecting “Delete all files”. This can take several seconds, depending on the amount of data stored. The event counters (see chapter 4.5) are also reset.

4.5. Event Reporting

In the measurement value display, press F2 for an overview of the warning and alarm events that have occurred. These are displayed together with the number of saved measured values.

```
ALARM STATISTICS
-----
Warning events: 745
Alarm events: 2501
Recordings: 10312
Sent SMS: 1

F1: Delete F3: Back
```

Figure 30: Event display

The sent SMS display is only available with VM40B.

4.6. Transferring the recorded data to a PC

For transferring saved data from the VM40 to a PC, a support program is available. This can be found on our website:

http://mmf.de/software_download.htm

The program converts the measurement data into a table of comma-separated values (CSV). This data format can be imported to all common table calculation programs such as Excel or OpenOffice Calc. This enables you to carry out your own analysis and generate reports according to your own requirements.

5. Relay Output

The VM40 has a relay output for controlling external signaling devices. These can be, for example, warning lights and acoustic signaling devices.

Please pay careful attention to the maximum contact load (see technical data, section 15). The relay output is not suitable for direct connection of mains operated devices.

To adjust the settings open the main menu and select “Alarms” and then “Relay output”. You can pre-set the relay to energize or de-energize when warning status (see Section 7.1) or alarm status occurs. (31).

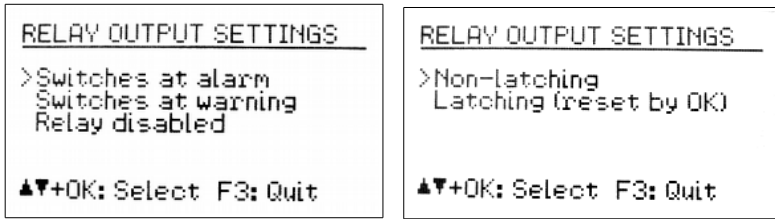

Figure 31: Relay output

In addition, you can determine whether the relay should stay energized (“Latching”) or de-energize after the event finishes, until the OK-button is pressed (“Non-latching”).

Note: The relay function will be activated after a delay of 30 seconds after leaving the menu.

Figure 32 shows the output socket and its contact assignment. In neutral (de-energized) position the contacts “C” and “n.c.” are connected, during warning or alarm status (energized) the contacts “C” and “n.o.” are connected.

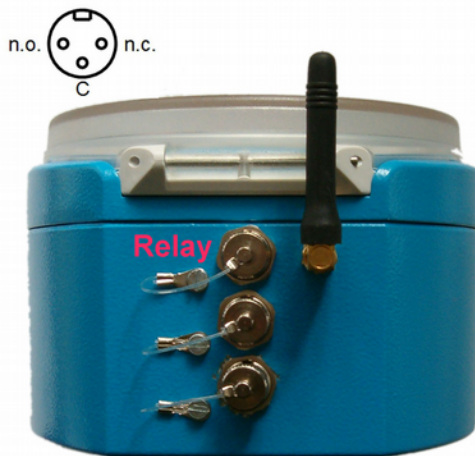

Figure 32: Relay output and terminal assignment (external view of the socket)

6. Receiving Alerts via SMS (VM40B)

6.1. General Information

The VM40B contains a GSM mobile phone modem for sending text message alerts when vibration events occur. In this way the VM40B is completely self-sufficient and can be used on far away grid-bound infrastructures.

The built-in modem supports the frequency bands 850, 900, 1800 and 1900 MHz and can, therefore, be used worldwide.

6.2. Inserting the SIM Card

To use the GSM functions a SIM card is needed. In order to insert the SIM card, the VM40 casing needs to be opened. To do this, unscrew the antenna and remove the transparent plastic cover by loosening four cross-headed screws (Figure 33).

Next, loosen the four cross-headed screws of the casing and carefully swing open the lid towards the connector side, at the same time ensuring you do not pull on the cables (Figure 34).



Figure 33: Removing the plastic cover and opening the casing

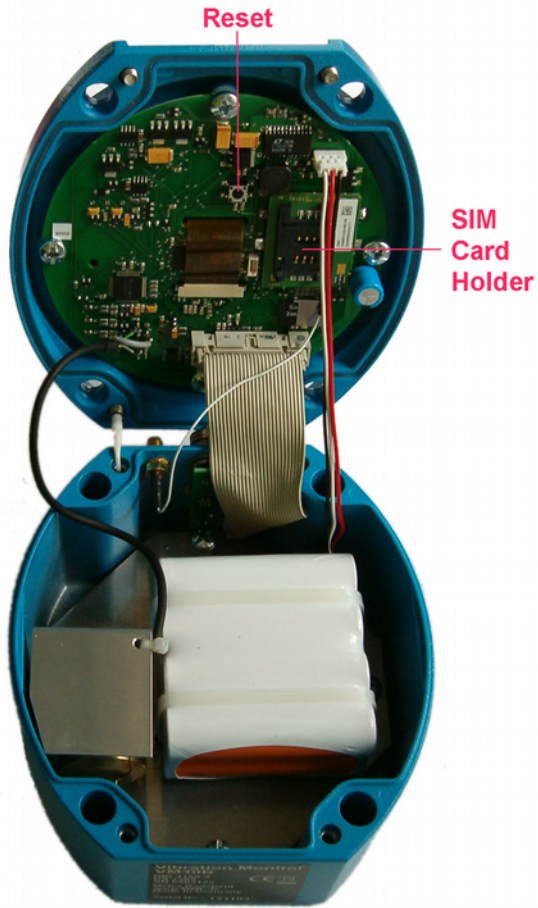

Figure 34: Opened lid

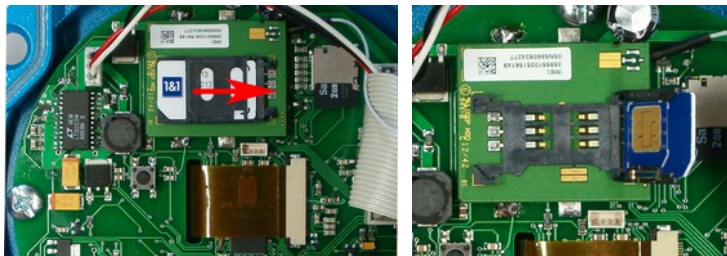

Figure 35: SIM Card holder

Open the SIM card holder by sliding its upper part across and opening it, as shown in Figure 35. Place the SIM card in the holder, as shown and close it again. Then put the lid back on again. Please ensure that you do not trap any cables while doing this and please check the position of the ribbon cable which establishes the connection to the sockets.

6.3. Connecting to a Mobile Phone Network

Once you have inserted the SIM card, open “Alarms/GSM” from the main menu and then select “GSM/SMS”.

When you use the card for the first time, you will be asked to enter the PIN. If the card has been locked (e.g. due to entering the wrong PIN three times), you will additionally need to enter the PUK number (Personal Unblocking Key) (Figure 36).

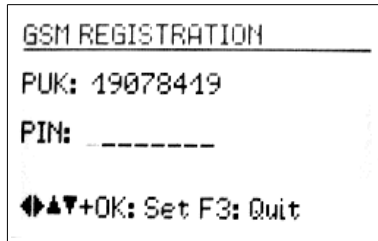

Figure 36: Entering the PUK and PIN

Note: The VM40B deactivates the password request after the first registration, so that the password does not need to be entered again.

Now the VM40B will try to connect to the mobile phone network. This takes a few seconds. If the registration is successful the name of the network provider will appear on the display (Figure 37).

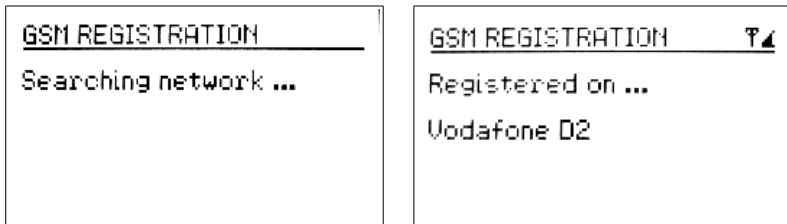

Figure 37: GSM Registration

The antenna symbol and the reception quality display, with five levels in the upper right corner of the display indicate the connection status. If the reception quality is too low, a question mark appears next to the antenna symbol.

Figure 38 shows the GSM settings menu.

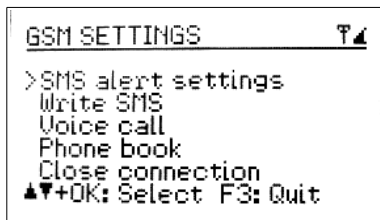

Figure 38: GSM Menu

Notice: GSM devices connect in regular intervals to the nearest cell tower at high transmission power. This is called Periodic Location Update (PLU). The length of these intervals may vary, depending on the network, between some minutes (rarely) and some hours. Problems occurred occasionally when cordless DECT telephones were located close to the VM40B. These use the same frequency band as GSM which may result in interferences causing false alarms in the PLU intervals. To avoid these it is recommended to remove DECT devices a few meters from the VM40B.

6.4. SMS Alerts

The VM40B can send SMS messages including measurement values and the time when a limit value is exceeded. To set up the automatic SMS alerts you need to enter the following information in the sub-menu “SMS Alert Settings” (Figure 39).

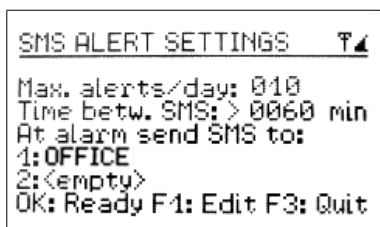

Figure 39: SMS Settings

Under the entry “Max. alerts/day” you can choose the maximum number of text messages the VM40B can send in one day. This allows you to control the connection costs.

Under “Time betw. SMS” you can set how many minutes the VM40 should wait before sending another SMS. This information also helps to avoid unnecessary costs or disturbances.

Furthermore, one or two telephone numbers need to be entered, to which the SMS messages should be sent. The numbers are selected from the phone book which is saved on the SIM Card (see Section 6.5).

Thirty seconds after leaving the menu the SMS alert function will be activated. During measurement operation this is indicated by an “S” displayed in the top left corner next to the antenna symbol. (40).

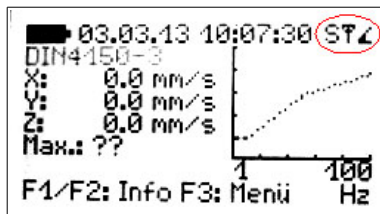

Figure 40: SMS Function display

The number of text SMS messages already sent can be viewed during measurement operation by pressing F2.



Figure 41: Number of messages sent

The message will be displayed on the receivers mobile (varying slightly dependent on the receiving phone) as shown in Figure 42.

Under the heading “!!VIBRATION ALERT!!” the instrument name is displayed (see Section 7.5). Below this the date and time of the alarm event are displayed, followed by the three vibration values measured at the time of the alarm signal. Lastly the main frequency and the remaining accumulator power of the VM40B are shown.

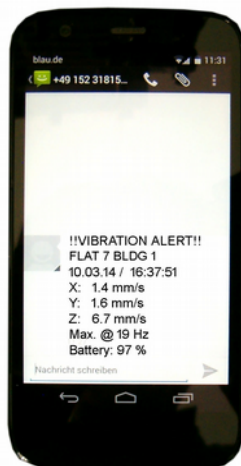

Figure 42: Example of received SMS message

6.5. Phone Book

The phone book is saved to the SIM card. If you have already contacts saved to the inserted SIM card, these will also appear in the VM40B. New contacts can be added to the phone book by the VM40B.

The phone book is found in the main menu under “Alarms/GSM”, sub-menu “GSM/SMS” and from there under “Phone book” (Figure 43). To edit the phone book you need to be connected to the network.

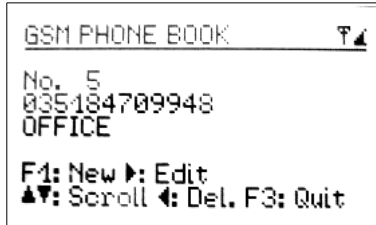

Figure 43: Phone Book

Press F1 to create a new entry. First enter the telephone number without spaces and then the name. Press OK to save the entry.

With the keys ▲▼ you can scroll through the existing entries.

Press ◀ to delete an entry.

Press ▶ to edit an existing entry.

The phone book can store a maximum number of 50 entries.

6.6. Writing an SMS

In the menu “Write SMS” under “Alarm/GSM”, sub-menu “GSM/SMS” you can write and send a short text message. You will then need to enter the receivers telephone number or select it from the phone book (Figure 44).

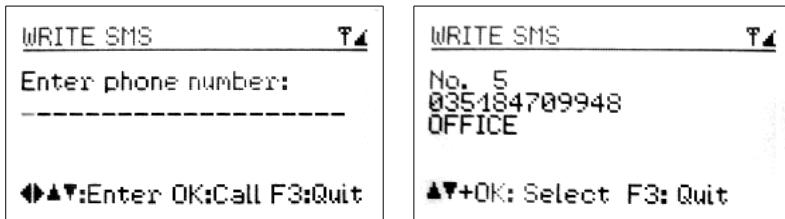

Figure 44: Enter receivers number or select from phone book.

Next you can enter 4 rows of text, each up to a maximum of 20 characters long. At the end of each row press OK. After entering the fourth row the message will be sent. (Figure 45).

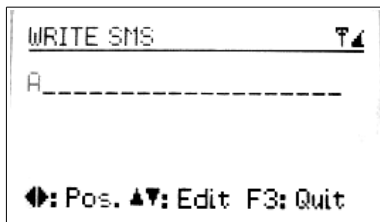

Figure 45: Write a short message

6.7. Calling

For making calls via the GSM modem you will need a standard PC headset, which can be connected to the second socket of the VM40B using the VM40-HS adapter. (Figure 46).

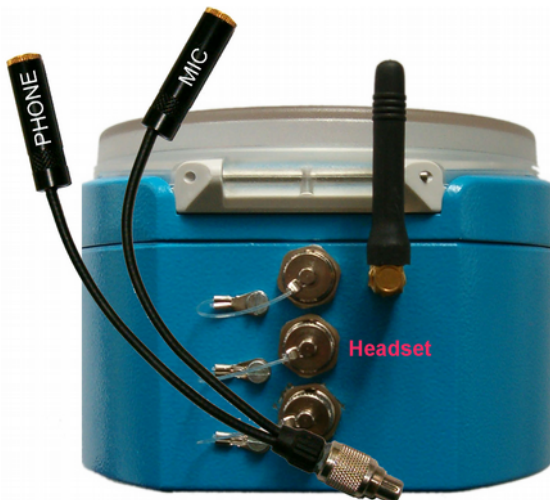

Figure 46: Headset Adapter and socket

You can select the telephone number from the phone book or enter it directly. (Figure 47).

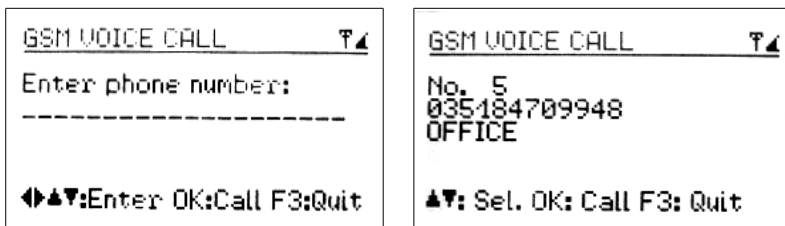

Figure 47: Enter phone number or select it from the phone book.

Press OK to connect the call. Press OK again to end the call.

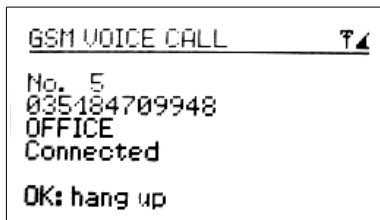

Figure 48: Telephone call

6.8. Close connection with mobile phone network

In the sub-menu “GSM/SMS” you will find the option “close connection”. Press OK to confirm you want close the connection with the mobile phone network (Figure 49). To prolong the life of the accumulator we recommend closing the connection with the mobile network when it is not being used. Keeping it connected runs down the accumulator more quickly.

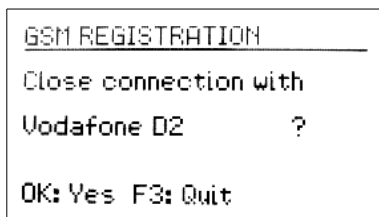

Figure 49: Close connection

7. Miscellaneous Settings

7.1. Warning Threshold

The warning threshold is an adjustable percentage value, which relates to the Alarm threshold of the selected standard (see Section 3). This enables you to automatically save measurement values or activate signaling at below the alarm limit of the applied standard.

If the warning threshold is exceeded the yellow light next to the display will flash.

To adjust the warning threshold, open the main menu by pressing F3, then select “Alarm/GSM” and “Warning Threshold (Figure 50).

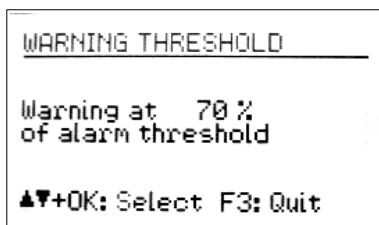

Figure 50: Warning Threshold

By pressing the keys ▲▼ you can set the value between 10 and 95 %.

7.2. Keypad Lock

To prevent manipulation during ongoing monitoring, it can be advantageous to activate the key lock. This function can be found in the main menu under “Key Lock” (Figure 51).



Figure 51: Key Lock

When the key lock has been activated, after leaving the menu you can only retrieve information using keys F1 and F2.

To release the key lock press all four arrow keys simultaneously, until the instrument displays “unlocked”.

Alternatively, the key lock can be switched on and off by a command sent via the USB interface.

7.3. Adjusting the Axes

The VM40 contains a tilt sensor for adjusting and monitoring the vertical alignment. The axes adjustment is located in the main menu under “Device settings”. There you will see a graph which resembles a spirit level (Figure 52). The moving point has to be located within the circle. If this is the case, “OK” will be displayed on the left of the screen.

To install/mount the VM40 on various floors or surfaces in conformity with a standard, Metra offers a tripod floor plate with adjustable feet.

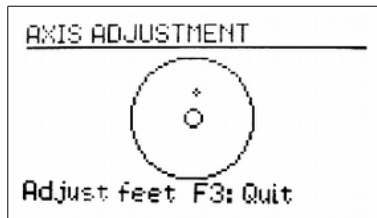

Figure 52: Axis adjustment

The axis adjustment is monitored during measurement operation. If the axes have been adjusted incorrectly, the flashing warning will appear in place of the standard “Adjust Axes!” (Figure 53).

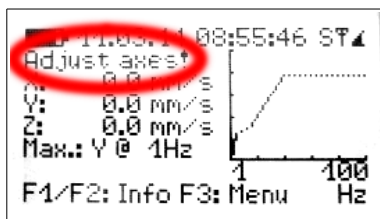

Figure 53: Warning "Adjust axes"

7.4. Date and Time

To retrace vibration events in the saved values the exact date and time are important. To set the data and time open the main menu, by pressing F3. From the main menu go to the menu option "Device settings" and press OK. From within this sub-menu go to "Date and time".

Use the keys ▲▼ to change the flashing value and with the keys ◀▶ move between second, hour, minute, month, day and year.

The date also takes the leap year in to account.

In the same menu you can also correct clock inaccuracy. This can be done using the setting at "Cal." in ppm (parts per million). The clock frequency can be increased with positive values and decreased with negative values. The sign changes to minus at +254 ppm.

Example: The clock is 5 seconds slow. There are $24 * 60 * 60 \text{ s} = 86400 \text{ seconds}$ in a day. The difference amounts to $5 \text{ s} / 86400 \text{ s} = 58 * 10^{-6} = 58 \text{ ppm}$. The adjustable value is -58 ppm. Press OK to apply the settings.

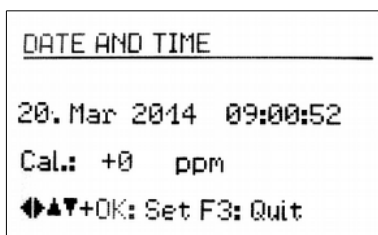

Figure 54: Date and Time

7.5. Instrument Name

The VM40 can be given an individual name, which, for example, identifies the location of installation. The instrument name is retrievable via the USB interface and is also used for the SMS alerts (VM40B) (see Section 6.4).

To enter the name open the main menu, go to "Device settings" and then to "Device name".

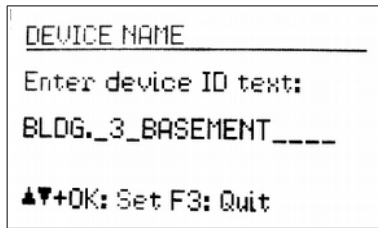

Figure 55: Device Name

Using the arrow keys you can enter us to 20 upper case characters and digits.

7.6. Menu Language

In the “Device settings” menu under “Menu language” you can choose between German and English.

8. Data Transfer

8.1. Connection to a PC

The VM40 has a USB interface. For connecting to a PC the VM2x-USB cable is provided (Figure 69), which is connected to the second socket on the VM40. As soon as the other end of the cable is connected to the computer USB socket, the device identification begins.

If the instrument is being connected to a PC for the first time you will be asked to carry out a driver installation. The required driver data MMF_VCP.zip can be found on our website:

http://mmf.de/software_download.htm

Save both data files in a directory on your computer.

When Windows requests details of the source of the device driver, this directory should be entered.

The device driver is digitally signed and runs with Windows XP, Vista, 7 and 8.

If the VM40 is connected to a PC, the signal “USB” appears on the measurement screen in place of the battery symbol. The battery power is then switched off and the instrument obtains its power supply via the USB connection.

8.2. Software VM40MDB

The PC software VM40MDB is used to archive and display measuring data from the VM40. In addition it generates reports in accordance with the relevant standards.

You can download the license-free software from the web page

http://mmf.de/software_download.htm#vm40

VM40MDB runs under Windows 7, 8 and 8.1.

Connect the VM40 to the USB port of the PC, switch it on and install the device driver, if necessary (see chapter 8.1).

Install VM40MDB and start it from the Windows start menu (Programs / Metra Radebeul). The main window will appear. (Figure 56).

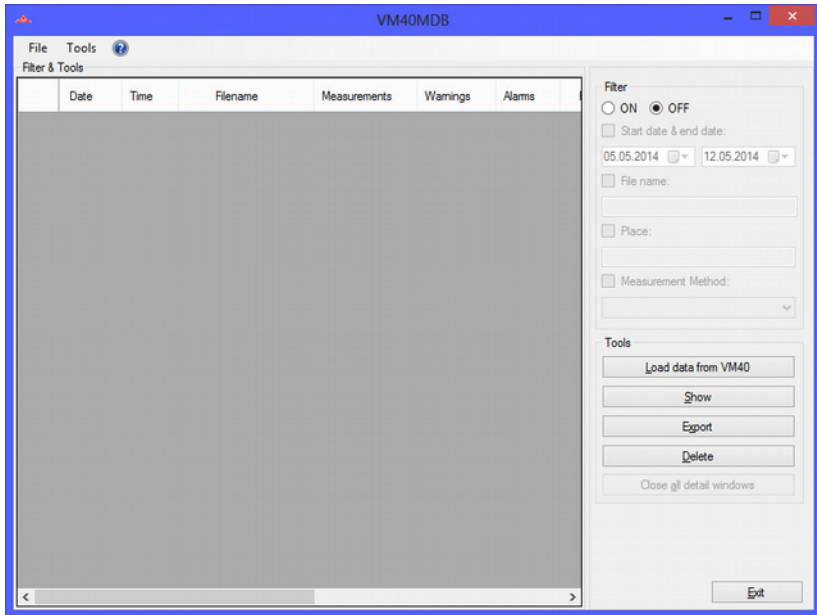

Figure 56: Main window without data

To start the transfer of data from the VM40 to the PC click “Load data from VM40”. The software will read header data first. Now you can select the files to be loaded by clicking the checkboxes (Figure 57).

Notice: The transmission of data from the VM40 to the PC is not possible while recording is active.

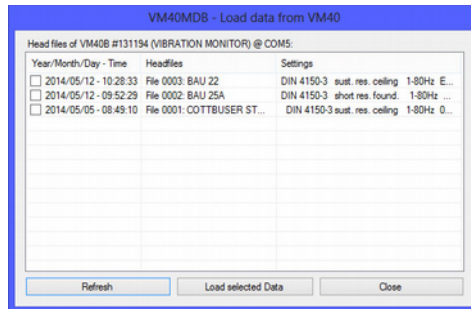

Figure 57: Selection of files

Click “Load selected data” to start the transfer. This may take up to some minutes for larger amounts of data. The progress is indicated above the list of header data.

| Date | Time | Filename | Measurements | Warnings | Alarms |
|------------|----------|---------------------|--------------|----------|--------|
| 05.05.2014 | 08:49:10 | COTTBUSER STR 29 OG | 41928 | 49 | 57 |
| 12.05.2014 | 09:52:29 | BAU 25A | 5 | - | 2 |
| 12.05.2014 | 10:28:33 | BAU 22 | 6 | - | 3 |

Figure 58: Imported data

VM40MDB can archive all measurements you have ever recorded with the VM40. They can also come from different VM40 units.

To search in larger amounts of data there are filter functions on the right side of the header list. You may search for a certain range of calendar dates, parts of the file name or the “place” text or for the measurement mode. The wild-card character “*” is allowed.

Select a record with the mouse pointer and click “Show”. A window showing “Properties” of the opened file will appear (Figure 59).

File COTTBUSER STR 29 OG: DIN 4150-3 @1-80 Hz (05.05.2014 - 08.49:10)

Properties | Measurement Chart | Measurements

Main properties

Filename: COTTBUSER STR 29 OG

Period: 05.05.2014 08:49:10 - 07.05.2014 15:51:26

Device: VM40B Serial number: 131194

Measurement method: DIN 4150-3 Frequency range: 1-80 Hz

Settings: sust. res. ceiling

Trigger mode: 005 + events

Measurement Summary

Measurements: 41928

Warnings (D-W): 49

Alarms (W-A, D-A): 57

Max. X-value: 97,62 mm/s

Max. Y-value: 93,31 mm/s

Max. Z-value: 113,94 mm/s

Optional Properties

Place: Fußbodenmitte in Raum 2

Comment:

Open protocol Export Cancel OK

Figure 59: File properties

You find the following information:

- Record name which was entered in the VM40 (see page 17)
- Period of recording
- Device name and serial number
- Used standard with detailed settings
- Record settings (triggers and interval)
- Number of saved measurements, warnings and alarms (colored)
- Maximum values for X, Y and Z

You may manually enter a description of the place of measurement, measuring conditions, etc. Two text fields are available for this purpose.

Click “Open protocol” to generate a report to DIN 4150-3, Appendix A. Under several menu tabs the necessary information is gathered (Figure 60). These include:

- Purchaser and person in charge
- Details about the source of vibration
- Description of the monitored structure
- Information about the location and the measuring point
- Environmental and other conditions
- Measuring results to be included

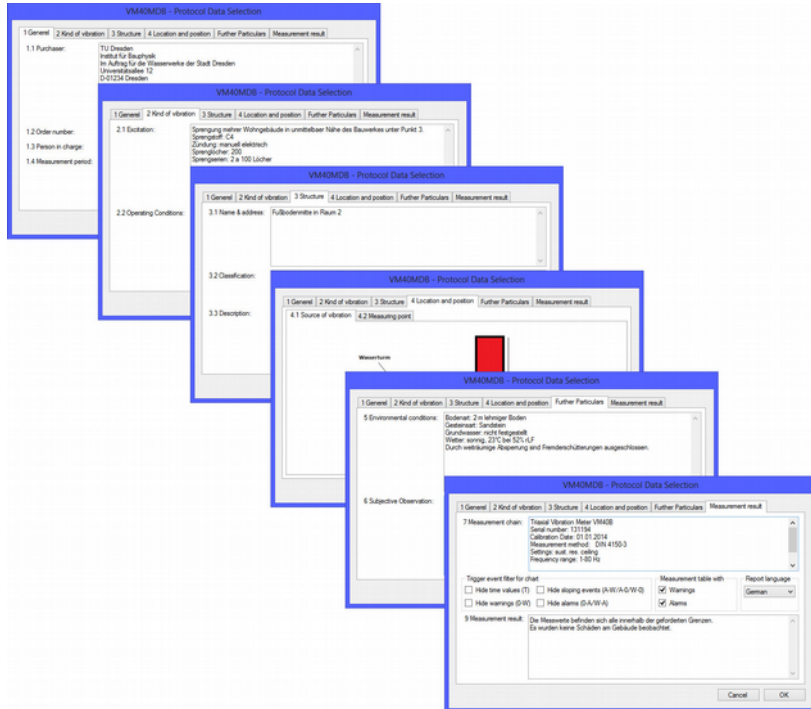

Figure 60: Entering data for the measuring report

In the menu “Location and position” pictures can be entered. Click inside the white space and load the image file from a specified storage position.

Press “OK” to complete the report. Figure 62 shows an example report.

The letter head of the protocol, including company address data and a logo, are entered in the menu “File” / “Settings” of the main window (Figure 61).

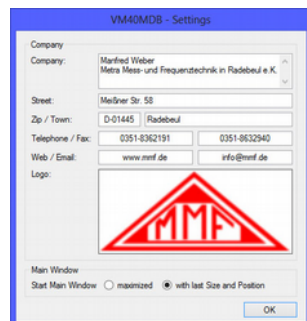

Figure 61: Protocol letter head

Measurement protocol

1 General

- 1.1 Purchaser: TU Dresden
 Institut für Bauphysik
 Im Auftrag für die Wasserwerke der Stadt Dresden
 Universitätsallee 12
 010124 Dresden
- 1.2 Order number: DK-2014/2348
- 1.3 Person in charge: Christian Richter
- 1.4 Measurement period: 05.05.2014 08:49:10 - 07.05.2014 15:52:36

2 Kind of vibration

- 2.1 Excitation: Sprengung mehrer Wohngebäude in unmittelbarer Nähe des Bauwerkes unter Punkt 3.
 Sprengstoff: C4
 Zündung: manuell elektrisch
 Sprenggelad: 200
 Sprenglöcher: 2 x 100 Löcher

- 2.1 Operating conditions: keine weiteren Erschütterungsquellen im Radius von 1 Kilometer.

3 Structure

- 3.1 Name and address: Fußbodenmitte in Raum 2
- 3.2 Classification: Baudenkmal nach DIN 4150-3
- 3.3 Description: Bauart: Wasserturmgebäude
 Größe: Grundfläche 20m x 20m / Höhe 30m
 Gründung: 289
 Baulicher Zustand: 1992 saniert, keine Schäden erkennbar.

4 Location and position

4.1 Source of vibration

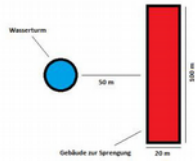

4.2 Measuring point



5 Environmental conditions

Bodenart: 2 m fehmiger Boden
 Gesteinsart: Sandstein
 Grundwasser: nicht festgesetzt
 Wetter: sonnig, 22°C bei 52% r.F.
 Durch weiträumige Absperrung sind Fremderschütterungen ausgeschlossen.

6 Subjective observations

An der Abzäunung (1 km von Sprengung entfernt) waren keine sekundären Nebeneffekte außer der Explosion an sich zu spüren.

7 Measuring chain

Triaxial Vibration Meter VM408
 Serial number: 131184
 Calibration date: 01.01.2014
 Measurement method: DIN 4150-3
 Settings: suit. res. ceiling
 Frequency range: 1-80 Hz
 Trigger mode: 005s + events
 Measurement processing and report generation done with VM408MS software.

8 Measurement result

8.1 Event chart

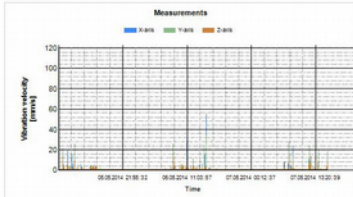

8.2 Single measurements

| Date | Time | X-axis [mm/s] | Y-axis [mm/s] | Z-axis [mm/s] | Frequency [Hz] | Trigger event |
|------------|----------|---------------|---------------|---------------|----------------|---------------|
| 05.05.2014 | 09:35:49 | 1,79 | 5,8 | 1,79 | 11 | Alarm (D-A) |
| 05.05.2014 | 09:42:49 | 2,26 | 6,19 | 2,11 | 9 | Alarm (D-A) |
| 05.05.2014 | 10:22:57 | 4,7 | 20,47 | 7,32 | 9 | Alarm (D-A) |
| 05.05.2014 | 10:32:45 | 5,18 | 1,52 | 1,26 | 3 | Alarm (D-A) |
| 05.05.2014 | 10:39:51 | 18,42 | 4,33 | 2,48 | 5 | Alarm (D-A) |
| 05.05.2014 | 11:22:48 | 9,54 | 2,13 | 1,6 | 11 | Alarm (D-A) |
| 05.05.2014 | 11:22:59 | 15,42 | 1,97 | 1,98 | 2 | Alarm (D-A) |

| | | | | | | |
|------------|----------|-------|-------|-------|----|-------------|
| 07.05.2014 | 12:19:45 | 0,30 | 5,77 | 13,43 | 11 | Alarm (D-A) |
| 07.05.2014 | 13:19:53 | 1,08 | 5,19 | 2,97 | 9 | Alarm (D-A) |
| 07.05.2014 | 13:41:33 | 5,55 | 8,75 | 2,97 | 11 | Alarm (D-A) |
| 07.05.2014 | 13:52:43 | 7,01 | 1,18 | 1,52 | 10 | Alarm (D-A) |
| 07.05.2014 | 13:53:51 | 5,44 | 2,09 | 2,55 | 9 | Alarm (D-A) |
| 07.05.2014 | 13:53:59 | 10,96 | 20,42 | 9,22 | 8 | Alarm (D-A) |
| 07.05.2014 | 15:44:36 | 8,57 | 18,34 | 4,08 | 2 | Alarm (D-A) |
| 07.05.2014 | 15:44:45 | 1,3 | 5,74 | 5,49 | 11 | Alarm (D-A) |
| 07.05.2014 | 15:47:31 | 1,94 | 6,11 | 5,04 | 8 | Alarm (D-A) |
| 07.05.2014 | 15:51:14 | 97,60 | 90,31 | 76,33 | 3 | Alarm (D-A) |
| 07.05.2014 | 15:51:25 | 7,84 | 4,69 | 2,12 | 2 | Alarm (D-A) |

9 Evaluation

Die Messwerte befinden sich alle innerhalb der geforderten Grenzen.
 Es wurden keine Schäden am Gebäude beobachtet.

10 Signs

Person in charge & stamp _____
 Purchaser _____

Figure 62: Example report (4 pages)

Apart from the report function you may display the measuring data graphically by selecting the menu tab “Measurement chart” (Figure 63). You will see all measurements in a magnitude/time diagram. Displayed events can be filtered depending on their trigger event. For example, you may want to see alarm events only. By right mouse click axes can be disabled. You may also save the diagram as image or in CSV table format to be further processed in Excel, OpenOffice Calc etc.

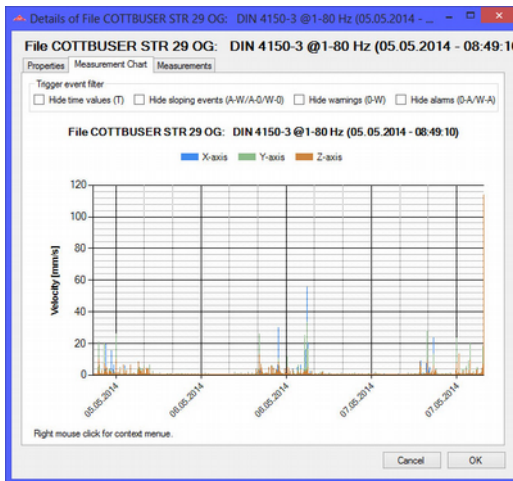

Figure 63: Measuring chart

Select the menu tab “Measurements” to switch to table view (Figure 64). Like in the diagram window you have the possibility to suppress certain kinds of events.

The screenshot shows a window titled "Details von Datei COTTBUSER STR 29 OG: DIN 4150-3 @1-80 Hz (05.05.2014 - ...)". The window has tabs for "Eigenschaften", "Messwertdiagramm", and "Messwerte". The "Messwerte" tab is active, displaying a table of measurement data. The table has columns for "Datum", "Uhrzeit", "X-Achse", "Y-Achse", and "Z-Achse". The data is as follows:

| Datum | Uhrzeit | X-Achse | Y-Achse | Z-Achse |
|------------|----------|---------|---------|---------|
| 05.05.2014 | 08:49:10 | 0.61 | 0.99 | 1.18 |
| 05.05.2014 | 08:49:15 | 0.58 | 1.23 | 0.61 |
| 05.05.2014 | 08:49:19 | 3.54 | 0.87 | 0.87 |
| 05.05.2014 | 08:49:25 | 0.33 | 0.34 | 0.17 |
| 05.05.2014 | 08:49:30 | 0.29 | 0.21 | 0.19 |
| 05.05.2014 | 08:49:34 | 0.24 | 0.17 | 0.16 |
| 05.05.2014 | 08:49:39 | 0.11 | 0.07 | 0.09 |
| 05.05.2014 | 08:49:44 | 0.11 | 0.08 | 0.07 |
| 05.05.2014 | 08:49:48 | 0.12 | 0.08 | 0.13 |
| 05.05.2014 | 08:49:53 | 0.1 | 0.11 | 0.1 |
| 05.05.2014 | 08:49:58 | 0.18 | 0.22 | 0.16 |
| 05.05.2014 | 08:50:02 | 0.08 | 0.13 | 0.11 |
| 05.05.2014 | 08:50:07 | 0.11 | 0.15 | 0.09 |
| 05.05.2014 | 08:50:13 | 0.07 | 0.13 | 0.16 |
| 05.05.2014 | 08:50:17 | 0.08 | 0.09 | 0.07 |
| 05.05.2014 | 08:50:22 | 0.23 | 0.09 | 0.07 |

Below the table, there are "Abbrechen" and "OK" buttons.

Figure 64: Table view

Notice: The frequency column shows “???” instead of a main frequency if the magnitude was too low to detect a main frequency.

If you click “Export” in the main window you will be asked to select the events to be saved into an export file (Figure 56). Available export formats are text and CSV.

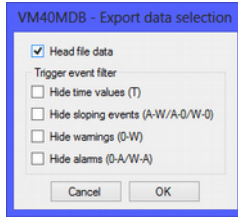

Figure 65: Selecting data for export

Finally, you may use the “Delete” button to erase data files from the VM40 memory.

9. Firmware Update

The device software (firmware) can be updated via the USB interface. First check whether an updated version of the currently installed software is available. This can be found on our website under:

http://mmf.de/software_download.htm

There you will see the most recently updated firmware version. The version number is composed of three digits for the hardware and three for the software (hhh.sss). Only the last three digits are relevant for the Firmware.

The currently installed version is displayed on the VM40 start screen.

If firmware with a higher version number is available on the website, please proceed as follows:

1. Download the firmware file `vm40.hex` from the above named internet address. This contains the firmware for the instruments VM40A and VM40B.
2. Also download the program “Firmware Updater” from the above named internet address and install it on your PC.
3. Connect the VM40 to the PC using the supplied USB cable and switch it on, by doing this the PC recognizes it as a USB device.

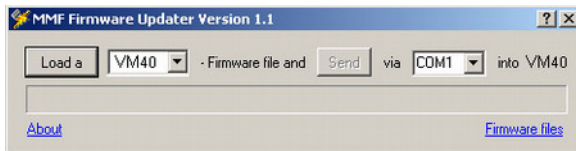

Figure 66: Firmware Updater

4. Start the “Firmware Updater”, then select the instrument type “VM40” and the virtual COM port assigned by the PC. If you are not sure which of the available COM ports is correct, you can check in the Windows system control manager located within the device manager.
5. Click on “Load” in the “Firmware Updater” and enter the path to the file where the downloaded firmware file `vm40.hex` is located.
6. Within the VM40 “Device settings” select the option “Update firmware” and confirm the subsequent warning by pressing OK (Figure 67). By carrying out

this step the old Firmware is deleted. The VM40 will then indicate that it is awaiting new Firmware data from the USB interface (“Waiting for update”).



Figure 67: Start update

7. Click on “Send” in the “Firmware Updater” and confirm the subsequent hint. Transfer of the firmware data has now begun. The transfer progress is displayed as a time bar on the PC and also on the VM40. When the update is finished the VM40 will carry out a new start and the “Firmware Updater” will close. Please do not interrupt the update process. After transfer failures the update can be restarted at point 3.

Important: Before starting an update please ensure that the battery is sufficiently charged. Otherwise the update may fail and can only be restored by the manufacturer.

10. Charging the Accumulator

The built-in NiMH accumulator has a capacity of 9 A h, which enables the VM40 to operate independently for more than 10 days. NiMH accumulators have a self-discharge rate of 0,5 to 1 % per day.

The charge status is displayed in the top left corner of the display. Shortly after the battery symbol displays empty, the VM40 switches off. The device measures according to the specification until it reaches this state.

To recharge the accumulator please connect the charger provided to the device via the charge socket (Figure 68).



Figure 68: Charge socket

After connecting up the charger you need to switch the device on in order to start the charging process. After a few seconds “Chg” appears in the top left corner of the

screen in place of the battery symbol. The accumulator has started charging, only when the “Chg” indicator appears and only while measurements are being displayed. If you open a menu or switch off the device the charging process will be interrupted.

If the accumulator is completely empty it takes approximately 10 hours to be fully recharged. You can continue measurement while the accumulator is being charged.

11. External Power Supply

For measurements of long duration an external power supply is recommendable.

To operate the VM40 using an external power supply, connect the USB cable provided via the device USB socket. (Figure 69).

To operate the device via a USB power supply you may use a standard USB power supply unit or alternatively a “USB Power Bank” accumulator. If the VM40 is connected via USB, the text “USB” appears on the measurement screen in place of the battery symbol. The internal accumulator then switches off and the VM40 receives its power via the USB connection.

Notice: The battery charger VM40-CH is not intended for permanent operation of the VM40 without battery load. Measurement can be continued with connected charger. However, each time the charge current is switched on or off the VM40 may detect false alarms.



Figure 69: USB Socket, USB Charger, Power Bank (e.g. 15 Ah) and USB Cable

12. Reset

In rare cases the VM40 may not respond to key pressure. You can restart the firmware by pressing the internal reset button. How to open the case is described in section 6.2. The location of the reset button is shown in Figure 71.

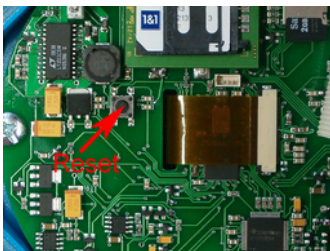

Figure 70: Reset button

Pressing the Rest button does not affect data in the memory. Only time and date need to be readjusted (chapter 7.4).

13. Mounting / Installation

The cast aluminum casing of the VM40 is suitable for direct mounting because of its weight. However, we recommend using the Tripod Floor Plate VM40-BP, available from Metra as a mounting accessory. (Figure 71). The VM40-BP has adjustable feet for aligning the axes, including exchangeable tips for different floor types.

At higher magnitudes the VM40 should be attached by screws. According to SN 640312a, free placement is not allowed at accelerations above 3 m/s^2 . The corresponding velocity is, for example, 24 mm/s at 20 Hz or 12 mm/s at 40 Hz .

For screw attachment the VM40 has four through-holes for screws up to M5 with a maximum head diameter of 8 mm. It is not necessary to open the casing in order to mount the device. Only the two gray plastic panels need to be removed, as shown in Figure 37 on page 23.



Figure 71: VM40 with Tripod Floor Plate VM40-BP
 Figure 72 shows a dimensional drawing of the mounting holes.

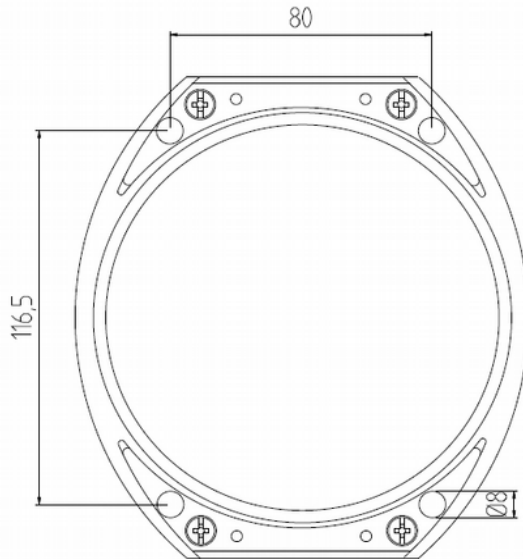

Figure 72: Dimensions of the mounting holes

14. Calibration

A VM40 distinguishing feature of the VM40 is its high long-term stability. Depending on the intensity with which it is used we recommend a recalibration after approximately 1 to 2 years. The month and year of the last calibration are displayed on the start screen.

The calibration is performed through mechanical excitation with known vibration amplitudes.

Due to the weight of the device and the required low frequencies and high amplitudes a particular kind of vibration exciter is needed.

The calibration menu is not accessible to the user in order to avoid manipulation

Metra offers a calibration service. For calibrations in other labs we also provide the necessary technical documentation, upon request.

15. Technical Data

| | |
|-----------------------------------|--|
| Measured value | Peak value of vibration velocity or vibration acceleration |
| Supported standards | DIN 4150-3; BS 7385; SN 640312a, Circulaire du 23/07/86 |
| Vibration Sensor | Triaxial piezoelectric shear type accelerometer |
| Display ranges (peak) | |
| Vibration acceleration: | 0.001 – 15 m/s ² |
| Vibration velocity: | 0.01 – 2400 mm/s at 1 Hz; 0.01 – 30 mm/s at 80 Hz (full-scale value frequency dependent) |
| Measurement accuracy | ±3 % ±20 digits at reference frequency 16 Hz, 100 Hz low pass pass ±3 % ±40 digits at reference frequency 16 Hz, 395 Hz low pass |
| Frequency ranges | 0.8- 100 Hz; 0.8 – 395 Hz, 5 – 150 Hz |
| Display | LCD, b/w, 128 x 64 pixels, back light 3 peak values (X/Y/Z) or vector sum significant frequency 50 lines FFT spectrum battery charge condition; date; time |
| Alarm signaling | Warning and Alarm LEDs next to the Display Relay output (change-over contact, max. 100 VDC / 2 A) |
| GSM modem (VM40B) | Quad-band (850, 900, 1800 und 1900 MHz) |
| SMS alarm function (VM40B) | SMS transmission at vibration events including X/Y/Z values, frequency, date, time, device name |
| GSM extra functions (VM40B) | phone call with connected headset (adapter VM40-HS); sending SMS text messages |
| Measurement value memory | Built-in Micro SD card max. 100 000 measurements (X/Y/Z, frequency, date, time, trigger event) |
| Analog/digital converter | 24 Bit, Sigma-Delta |
| USB interface | USB 2.0 Full-Speed, CDC mode, via cable VM2x-USB |
| Accumulator | NiMH, 4.8 V / 9 Ah, charging duration: approx. 10 h; buffered operation without accumulator load by USB power; (e.g. USB mains adapter or USB power bank) |
| Battery operating life per charge | 10 – 15 days, depending on temperature, GSM usage (VM40B) and display light duration |
| Menu language | English / German |
| Operating temperature range | - 20 – 60 °C |
| Dimensions | 150 mm x 140 mm x 80mm |
| Weight | 2 kg |
| Accessories included | USB Cable VM40 USB Battery charger VM40-CH |
| Optional Accessories | Tripod Floor Plate VM40-BP Headset Adapter VM40-HS |

Limited Warranty

Metra warrants for a period of
24 months

that its products will be free from defects in material or workmanship and shall conform to the specifications current at the time of shipment.

The warranty period starts with the date of invoice.

The customer must provide the dated bill of sale as evidence.

The warranty period ends after 24 months.

Repairs do not extend the warranty period.

This limited warranty covers only defects which arise as a result of normal use according to the instruction manual.

Metra's responsibility under this warranty does not apply to any improper or inadequate maintenance or modification and operation outside the product's specifications.

Shipment to Metra will be paid by the customer.

The repaired or replaced product will be sent back at Metra's expense.

Declaration of Conformity

According to EMC Directive 2014/30/EC

Product: Triaxial Vibration Monitor
Type: VM40A/VM40B (from Ser. no. 160000)

It is hereby certified that the above mentioned products comply with the demands pursuant to the following standards:

DIN EN 61326-1: 2013

DIN EN 61010-1: 2011

DIN 45669-1: 2010

The producer is responsible for this declaration

Metra Mess- und Frequenztechnik
in Radebeul e.K.

Meißner Str. 58, D-01445 Radebeul

declared by



Michael Weber
Radebeul, April 22, 2016