



# Instruction Manual

## IEPE Conditioning Module M32

### Application

The IEPE Conditioning Module M32 is a signal conditioner for transducers with IEPE compatible output. It provides the necessary power supply for the electronic circuit of the sensor. The unit features 3 gain ranges and a plug-in low pass filter. The M32 can be used as a front end for PC based data acquisition systems. It can be combined with the IEPE Supply Module M28. The M32 is suited for both benchtop applications and DIN rail attachment in switch cabinets. The wide supply voltage range of the M32 allows power supply from external batteries, from the available mains plug adapter or from an industrial 24 VDC supply.

### What is IEPE?

IEPE is a well-established standard for the output of piezoelectric transducers and microphones. It stands for "Integrated Electronics Piezo Electric". Other brand names for the same principle are ICP<sup>®</sup>, Isotron<sup>®</sup>, Delta-tron<sup>®</sup>, Piezotron<sup>®</sup> etc. The integrated circuit of the sensor transforms the charge signal of the piezo-ceramic sensing element, with its very high impedance and high EMI sensitivity, into a voltage signal with low impedance.

A special feature of the IEPE electronics is that power supply and measuring signal are transmitted via the same cable. So, an IEPE transducer requires, like a transducer with charge output, only one single-ended shielded cable.

Figure 1 shows the principle circuit diagram. The integrated sensor electronics is supplied with constant current. This should not be confused with a 4-20 mA current loop. The constant current  $I_{const}$  is fed into the signal cable of the sensor. A de-coupling capacitor keeps DC components away from the signal conditioning circuit.

The constant current supply and de-coupling capacitor are part of the M32.

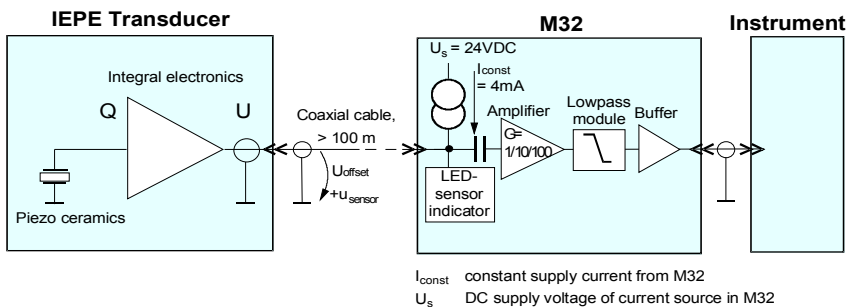

Figure 1: IEPE principle and functional diagram of the M32

By supplying the sensor with constant current a positive DC offset voltage arises at the sensor output. This DC voltage depends on the manufacturer and the specimen and reaches 5 V to 14 V. Round this bias voltage the measuring signal of the transducer may oscillate. The output voltage of the transducer never changes to negative values. Its minimum value is the saturation voltage of the integrated electronics (about 1V). The maximum value of the output voltage is limited by the supply voltage of the constant current source (24 VDC with the M32). Figure 2 shows the dynamic range of the transducer. The output of the M32 is free of DC components. It provides the unaltered AC sensor output signal.

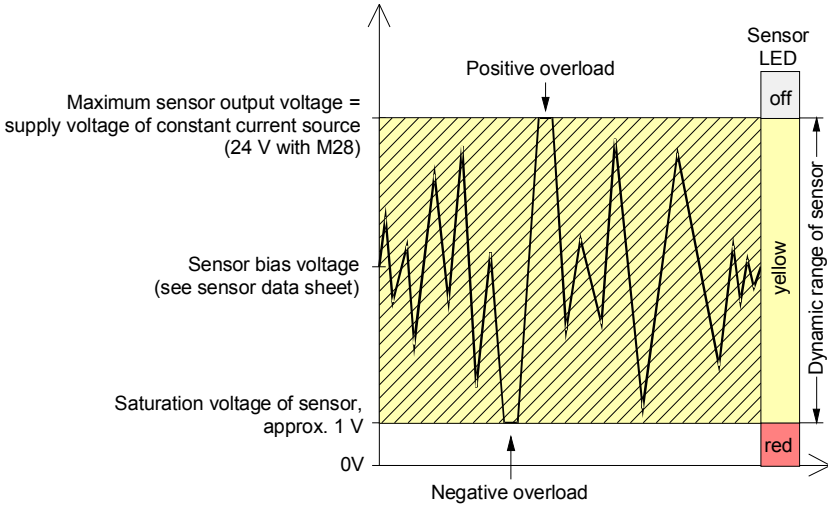

Figure 2: Dynamic range of IEPE sensors

## Description

The IEPE Conditioning Module M32 (Figure 3) contains the electronic circuit for supplying one sensor. For multichannel applications additional M28 modules can be plugged into one another by means of screwed in banana plugs at the side wall of the instrument. These plugs connect the power supply voltage to all modules.

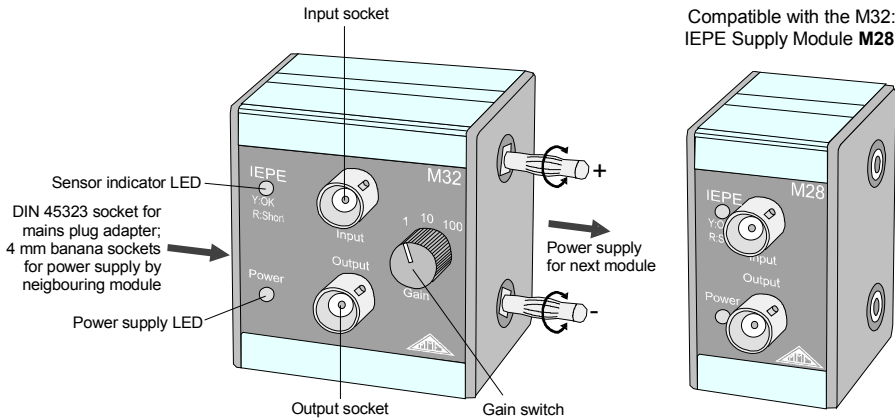

Figure 3: Functions of the M32

The M32 requires for operation a supply voltage between 5 and 26 VDC. It can be powered, for example, by:

- Industrial 24 VDC supplies
- The optionally available mains plug adapters **PS500** (for one M32) and **PS1000** (for up to 3 units M32)
- Batteries with more than 5 VDC
- PC or USB voltage (5 or 12 VDC)

The operating voltage is connected via a circular power connector to DIN 45323 on the left side of the M32. The tip (inner conductor) is the positive terminal. Alternatively the two banana sockets on the left side of the case can be used for power supply. Their polarity is shown in Figure 3. A green „Power“ LED indicates the connected supply voltage.

The M32 is protected against false polarization and line transients up to 60 V. Insulation between power supply and measuring signal is provided.

A supply voltage of 24 VDC for the constant current source is internally generated. This voltage is sufficient for an optimal dynamic range with all available IEPE compatible transducers. The constant current of the M28 is approximately 4 mA.

An LED sensor status indicator informs the user of the following conditions: (compare Figure 2):

- LED off: No sensor connected or sensor circuit interrupted.
- LED yellow: Sensor connected properly with bias voltage between 1 and 24 VDC.
- LED red: Input shorted, voltage below 1 VDC.

The gain of the M32 can be selected by a rotary switch between 1, 10 and 100.

The M32 is suited for measurements with piezoelectric transducers from 0.1 Hz to 30 kHz. Thus seismic measurements at low frequencies with accelerometers or quasi static pressure and force measurements can be performed. Also shock measurements involving high frequencies and amplitudes are possible with the M32.

The M32 has a replaceable low pass filter module type **FB2-...** with 4<sup>th</sup> order Butterworth characteristics. Metra offers a variety of filter modules with cut-off frequencies between 100 Hz and 30 kHz. By unscrewing the rear panel and sliding it off the filter module becomes visible (Figure 5). Before replacing the filter, the power supply must be unplugged. Please make sure that the marking “Pin 1” is in the same position as the marking on the PCB. The frequency label supplied with the filter module can be attached to the blank field at the rear panel.

The M32 is well suited for 35 mm DIN rail attachment (Figure 4). For this purpose the adapter **M28+32DIN** is available. The adapter base is mounted on the M32 by 2 screws M2.5. Two tapped holes are provided at the rear of the instrument. As second step the DIN rail bracket is attached by one screw M3.

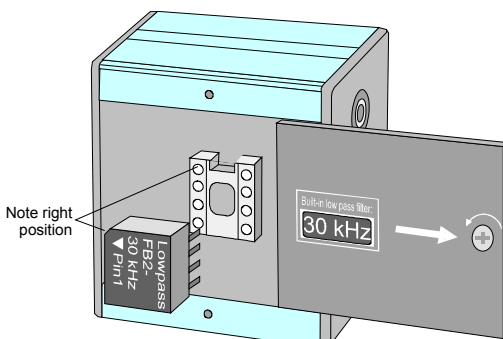

Figure 5: Replacing the filter module

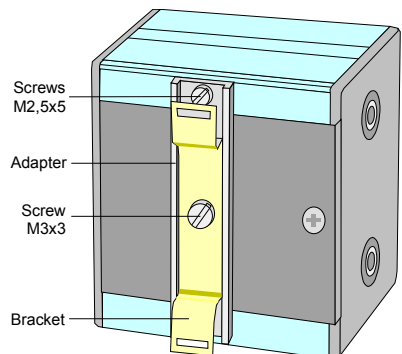

Figure 4: DIN rail adapter M28+32DIN

# Technical Data

Input / output:	BNC sockets
Output circuit:	DC coupled; impedance approx. 100 $\Omega$
Dynamic range:	$\pm 10$ V
Constant current source:	3.8 .. 5.6 mA, compliance voltage >24 V
IEPE sensor indicator:	Bicolor LED; off = open input; yellow = 1 .. 24 V = OK; red = shorted
Gain ranges:	1 / 10 / 100 $\pm 1$ % typically; $\pm 2$ % maximum
Output noise:	< 1 mV <sub>rms</sub> with 30 kHz low pass
Frequency range (- 3 dB):	0.1 Hz .. 30 kHz (depending on lowpass module)
Low pass filter:	Plug-in module <b>FB2-...</b> ; Butterworth; 4 <sup>th</sup> order; attenuation > 70 dB/decade available frequencies (-3 dB): FB2 - 0.1 / 0,3 / 1 / 3 / 5 / 10 / 30 kHz
Power supply:	U <sub>S</sub> = 5 .. 26 VDC; < 200 mA; insulated from signal path; via DIN 45323 circular power connector (positive terminal at tip) or two banana plugs
Case:	Aluminum, connected to negative terminal of power supply
Included accessories:	2 screw-in banana plugs for power supply connection with other modules
Optional accessories:	<b>PS500:</b> mains plug adapter for 100 .. 240 VAC; 12 VDC / 500 mA sufficient for one unit M32 <b>PS1000:</b> mains plug adapter for 100 .. 240 VAC; 12 VDC / 1000 mA sufficient for up to 3 units M32 <b>M28+32DIN:</b> 35 mm DIN rail adapter
Operating temperature:	-10 .. 55 - C; 95 % relative humidity; no condensation
Weight:	170 g
Dimensions (W x H x D):	56 mm x 59 mm x 44 mm

## Warranty

Metra warrants for a period of

**24 months**

That its products will free from defects in material and workmanship and shall conform to the specifications current at the time of shipment. The warranty period starts with the date of invoice.

The invoice must be presented as proof of purchase.

The warranty period ends after 24 months.

Repairs do not extend the warranty period.

The limited warranty only covers defects which arise as a result of normal use according to the instruction manual.

Metra's obligations under this warranty do not apply in cases of improper or inadequate maintenance or modification and operation outside the product's specifications

Shipment to Metra will be paid by the customer.

The repaired or replaced product will be sent back to the customer at Metra's expense.

## Declaration of Conformity

According to EMC Directive 2014/30/EC

Product: IEPE Conditioning Module

Type: M32

It is hereby certified that the above mentioned product complies with the demands pursuant to the following standards:

DIN EN 61326-1: 2013

DIN EN 61010-1: 2011

DIN 45669-1: 2010

The producer is responsible for this declaration

Metra Mess- und Frequenztechnik  
in Radebeul e.K.

Meißner Str. 58, D-01445 Radebeul

declared by



Michael Weber  
Radebeul, 3<sup>rd</sup> March 2016